

GASGUARD NH₃ 2% EXP

Ammonia Sensor



OPERATING & INSTALLATION MANUAL

**CALIBRATION
TECHNOLOGIES
INC.**

Warning

Use this product only in the manner described in this manual. If the equipment is used in a manner not specified by Calibration Technologies, the protection provided by the equipment may be impaired.

This equipment should be installed by qualified personnel.

Table of Contents

General description	4
Installation.....	4
Locating the sensor	4
Installation guidelines.....	5
Wiring.....	6
Operation	7
Start-up	7
Calibration	7
Maintenance.....	9
Specifications.....	10
Warranty.....	11

For technical support, contact:

Calibration Technologies

920 N Trade Winds Pkwy
Columbia, MO 65201

866-394-5861

sales@CTIengineering.com

www.CTIengineering.com

General Description

The GasGuard NH₃ 2% EXP sensor is a +24 VDC, three-wire, 4/20 mA sensor for detection of ammonia gas in hazardous locations. It is designed to detect and monitor potentially explosive levels of ammonia vapors in air over the range of 0-20,000 ppm. It provides an industry standard linear 4/20 mA output signal compatible with most gas detection systems and PLCs.

The GG-NH₃-2%-EXP provides real-time continuous monitoring of high concentrations of ammonia utilizing catalytic bead sensor technology. The aluminum enclosure includes a 3/4" NPT female conduit port and is rated for Class 1, Div 2, Groups B, C & D locations (see Specifications on page 10 for details).

Codes specify compressors, pumps and normally closed valves in the compressor room to be de-energized at a level not higher than 25% LEL (4% or 40,000 ppm) to remove potential ignition sources in the event of a serious ammonia leak. When mixed with oil, ammonia can have an even lower explosive limit. Calibration Technologies recommends an alarm setpoint at 2% which adds an extra safety factor for any leak scenario. While primary applications for the GG-NH₃-2%-EXP sensor are E-stop applications for compressor rooms, it can be used almost anywhere high concentrations of ammonia vapors need to be detected or monitored.

Installation

Locating the sensor

One of the most important considerations when installing the GG-NH₃-2%-EXP sensor is that it must be easily accessible for calibration and maintenance.

Depending on the location of the ammonia leak and whether it is liquid or vapor, higher concentrations can be found higher or lower in a compressor room. Calibration Technologies recommends mounting the sensor five feet off of the floor for easy access.

Alternatively, the sensor can be mounted close to the emergency exhaust fan to ensure the room air is drawn across the sensor once the fan is activated. Since exhaust fans are typically located towards the ceiling, ensure the sensors remains easily accessible.

As a general rule of thumb, try to mount sensors within 30 feet of potential leak sources.

Installation Guidelines:

- Always mount the sensor vertically with sensor pointed down.
- Must be easily accessible for calibration and maintenance.
- Mount the sensor close to the potential leak source.
- Take air movement and ventilation patterns into account.
- To prevent electrical interference, keep sensor and wire runs away from mercury vapor lights, variable speed drives, and radio repeaters.
- Protect sensor from physical damage (forklifts, etc.)
- If mounting on a wall with studs, the mounting screws should be screwed into the studs.
- Mount sensor enclosure through the mounting holes as shown in **Figure 1**.

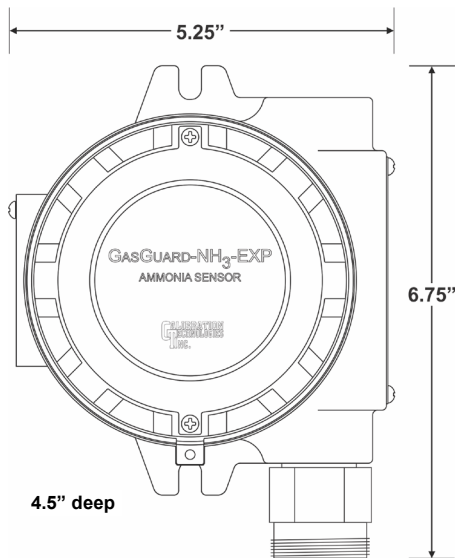

Figure 1: Mounting dimensions

Wiring

Electrical wiring must comply with all applicable codes.

Electrical Power: 24 VDC regulated, 80 mA.

Output: Linear 4/20 mA output. Monitoring equipment may have a maximum input impedance of 700 ohms.

Cable Recommendation: 20/3 shielded cable (General Cable C2525A or equivalent). Length of cable to sensor should be no greater than 1,500 feet.

Monitoring: Monitoring equipment must be configured to indicate a fault if the signal is below 1 mA. All signals over 20 mA must be considered high gas concentrations. Alarm setpoints should not be lower than 10% of full-scale range.

Wiring Guidelines:

- Always use 3-conductor, insulated, stranded, shielded copper cable.
- Do not pull sensor wiring with AC power cables. This can cause electrical interference.
- If cable runs cannot be made without a splice, all splice connections should be soldered.
- Ground the shield at the main control panel. Connect the shield wire in the sensor terminal block labeled *SHLD*.
- Always disconnect power at the controller before performing any wiring at the sensor.
- To maintain certification rating of the enclosure, conduit fittings of the same rating or better must be used.

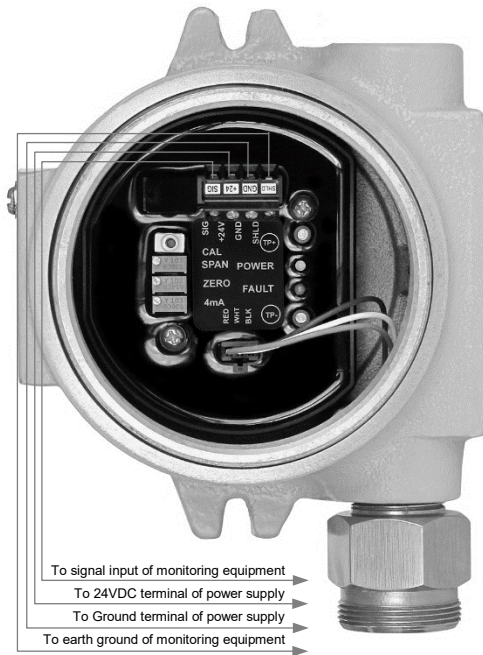

Figure 2: Wiring diagram

Operation

Start-up

Note: Ensure area is free from explosive gases before removing cover while sensor is energized.

Before applying power, make a final check of all wiring for continuity, shorts, etc. Because sensors are normally located at a distance from the main unit, the test time required and accuracy of the response checks will be improved if two people perform the start-up procedures and use radio contact.

Note: Sensor can be response tested immediately after power up. Allow sensor to stabilize for 1 hour before making any zero or span adjustments.

Start-Up Test:

- 1) One person exposes each sensor to calibration gas or ammonia/water solution.
- 2) The second person stays at the control unit to determine that each sensor, when exposed to the gas, is connected to the proper input and responds, causing appropriate alarm functions.

Calibration

The GG-NH₃-2%-EXP sensor comes factory calibrated and should require only minimal adjustments after installation. Calibration should be performed six months after installation. There are two potentiometers on the preamp that are used for calibration (see **Figure 3**).

Note: Never measure sensor output in mA. Always use mVDC or VDC voltmeter settings.

Calibration Mode: Cal mode is required for calibrating the sensor. It clears the deadband (factory set at 4.8 mA) and averaging. Pressing the CAL switch enables cal mode and the green LED will flash. To exit out of cal mode, press the CAL switch or after 6 minutes it will automatically time-out.

Zero Calibration: After the unit is installed and has been powered up for a minimum of 1 hour, the unit can be zero calibrated by the following:

- Be sure the unit is in clean air.
- Press the CAL switch once to enter cal mode. Do not adjust the zero pot if the green LED is not flashing.
- Adjust the zero pot until the sensor outputs 40 mV from Test [-] to Test [+] (see **Figure 3**).

Span Calibration: DO NOT ADJUST THE SPAN POT WITHOUT CERTIFIED CALIBRATION GAS! Do not remove sensor housing cap during calibration. If span adjustment is required, the following procedure will span the unit:

- Apply 2% NH₃ span gas at 0.8 L/min (span gas must be in air, not nitrogen or other carrier).
- Sensor should react to gas within 15 seconds.
- Once the output signal has peaked (or 2 minutes maximum) adjust the span pot until the correct output is achieved (200 mV) (see **Figure 3**).
- Calibration is now complete.

Green LED indicates power
Red LED indicates hardware fault

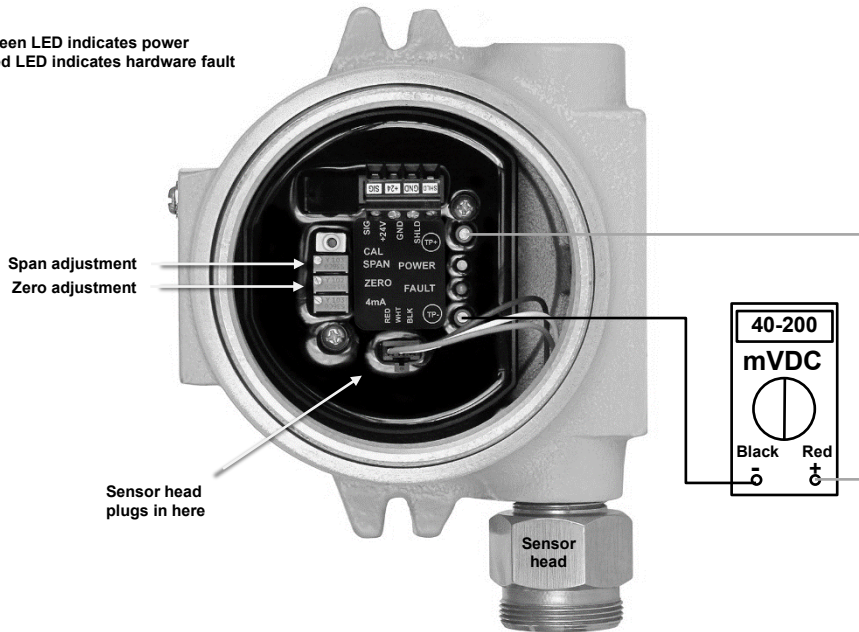

Figure 3: Sensor board components and zero/span adjustments

4mA adjustment: Sometimes a fine adjustment of the 4mA signal may be desired to compensate for a slight positive or negative zero-signal reading on the control panel.

- Make sure the sensor is NOT in calibration mode.
- Adjust the 4mA pot until the control panel reads zero.

Sensor replacement: If sensor replacement is required, follow the procedure below.

Note: Ensure area is free from explosive gases before proceeding.

- Unscrew the sensor cover.
- Unplug 3-position sensor plug from transmitter.
- Unscrew sensor head from enclosure and discard.
- Carefully install new sensor and plug into transmitter.
- Refer to calibration section on page 7 to calibrate new sensor.

Note: Below are a few response characteristics which may be an indication that the gas sensor is at or near the end of its useful life. If any of these are observed, the sensor should be replaced:

- Slow response to / recovery from calibration gas.
- Failure of the output to reach 50% of the calibration gas value prior to span adjustment.
- Unable to achieve 200mV during span adjustment.

Maintenance

The GG-NH3-2%-EXP was designed for long life and minimal maintenance. For proper operation it is essential that the test and calibration schedule be adhered to. Calibration Technologies recommends the following maintenance schedule:

Maintenance Guidelines:

- The sensor is shipped with a factory calibration. Sensor should be calibrated 6 months from purchase date and every 6 months afterwards to correct for sensor aging characteristics.
- Calibration should be performed with certified calibration gas. Calibration kits and replacement cylinders are available from CTI.
- In highly critical areas, a response test should be performed between calibrations to verify proper sensor response and alarm functions. This can be done with 2% NH₃ calibration gas. The response test is not required if multiple sensors are installed in the same room.
- All tests and calibrations must be logged.
- Always disconnect power at the controller before performing any wiring at the sensor.

Specifications

Input Power: +24 VDC, 80 mA

Detection Principle: Catalytic Bead

Detection Method: Diffusion

Gases: Ammonia (NH₃)

Ranges: 0/2% (0/20,000 ppm)

Output Signal:

Linear 4/20 mA (max input impedance: 700 Ohms)

Response Time:

T₅₀ = less than 30 seconds; T₉₀ = less than 60 seconds

Accuracy: +/- 5% of value

Zero Drift: Less than 0.1% of full-scale per month

Span Drift: Less than 2% per month

Linearity: +/- 0.5% of full-scale

Repeatability: +/- 1% of full-scale

Wiring Connections:

3-conductor, shielded, stranded, 20 AWG cable
(General Cable C2525A or equivalent) up to 1500 ft.

Terminal Block Plug (Field Wiring): 26-12 AWG,
torque 4 lbs-in.

Temperature Range: -40°F to +120°F (-40°C to +49°C)

Humidity Range: 5% to 100% condensing

Dimensions: 6.75" high x 5.25" wide x 4.5" deep

Weight: 3.75 lbs

Sensor Head: Stainless steel flameproof enclosure
constructed with an integral stainless steel sinter filter
for the safe entry of the atmosphere being detected.

ATEX Certificate CESI 01 ATEX 066 U

Enclosure: Copper-free aluminum body, epoxy powder
coat finish, neoprene gasket, for hazardous areas.

NEC/CEC:

Class I, Division 2, Groups B, C, D

Class II, Division 1, Groups E, F, G

Class II, Division 2, Groups F, G

Class III

NEMA/EEMAC: 3, 4, 4X, 7BCD, 9EFG

UL Standard: 1203

CSA Standard: C22.2 No. 30

FM Classification No.: 3615

ATEX Certificate KEMA 02 ATEX 2265U

IEC Standards EN:60079-0, EN:60079-1, EN:60529

Limited Warranty & Limitation of Liability

Calibration Technologies, Inc. (CTI) warrants this product to be free from defects in material and workmanship under normal use and service for a period of 2 years (including gas sensor), beginning on the date of shipment to the buyer. This warranty extends only to the sale of new and unused products to the original buyer. CTI's warranty obligation is limited, at CTI's option, to refund of the purchase price, repair, or replacement of a defective product that is returned to a CTI authorized service center within the warranty period. In no event shall CTI's liability hereunder exceed the purchase price actually paid by the buyer for the Product.

This warranty does not include:

- a) routine replacement of parts due to the normal wear and tear of the product arising from use;
- b) any product which in CTI's opinion, has been misused, altered, neglected or damaged by accident or abnormal conditions of operation, handling or use;
- c) any damage or defects attributable to repair of the product by any person other than an authorized dealer or contractor, or the installation of unapproved parts on the product

The obligations set forth in this warranty are conditional on:

- a) proper storage, installation, calibration, use, maintenance and compliance with the product manual instructions and any other applicable recommendations of CTI;
- b) the buyer promptly notifying CTI of any defect and, if required, promptly making the product available for correction. No goods shall be returned to CTI until receipt by the buyer of shipping instructions from CTI; and
- c) the right of CTI to require that the buyer provide proof of purchase such as the original invoice, bill of sale or packing slip to establish that the product is within the warranty period.

THE BUYER AGREES THAT THIS WARRANTY IS THE BUYER'S SOLE AND EXCLUSIVE REMEDY AND IS IN LIEU OF ALL OTHER WARRANTIES, EXPRESS OR IMPLIED, INCLUDING BUT NOT LIMITED TO ANY IMPLIED WARRANTY OF MERCHANTABILITY OR FITNESS FOR A PARTICULAR PURPOSE. CTI SHALL NOT BE LIABLE FOR ANY SPECIAL, INDIRECT, INCIDENTAL OR CONSEQUENTIAL DAMAGES OR LOSSES, INCLUDING LOSS OF DATA, WHETHER ARISING FROM BREACH OF WARRANTY OR BASED ON CONTRACT, TORT OR RELIANCE OR ANY OTHER THEORY.

GG-NH3 2%-EXP-DOC1-0
20160928



SPECIALISTS IN
GAS DETECTION